



www.pbsc.co.uk
www.pbsc-inc.com

AR-H/Ht
Wall Mounted & Trolley Hatch

AR-H/Ht

Wall Mounted & Trolley Hatch

PBSC provide installation, servicing, technical advice, product selection and demonstrations for clean controlled environments with **Innovation, Design and Quality** at the heart.

PBSC manufacture high quality clean room, high containment and material decontamination products. When you need areas and staff to be contamination free and protected from pathogens, you need dependable equipment which will maintain critical biosafety levels, achieve sterility and protect data reliability.

Complying with local and global regulations **PBSC's** products can be designed to meet your specific requirements. Over 30 years knowledge and competence within the specialist sectors, always going through extensive research and development and offering accurate assistance during project planning to consultants, architects and end users to deliver successful projects.



Innovation

Incorporating your requirements to create product ranges to exceed expectations



Design

Leading the way with pioneering design, ensuring customer requirements are achieved



Quality

Delivering high quality products for over 30 years, with rigorous testing and inspection

PBSC is the accepted benchmark by which others are measured...

The search for innovative design, an eye for detail and advanced manufacturing techniques has seen **PBSC** gain a deserved reputation as the premier supplier within cleanroom environments.

Supporting the customer throughout the process continuing to meet the growing challenges and striving for continual improvement with our ISO 9001 QA processes independently audited and updated on a regular basis.

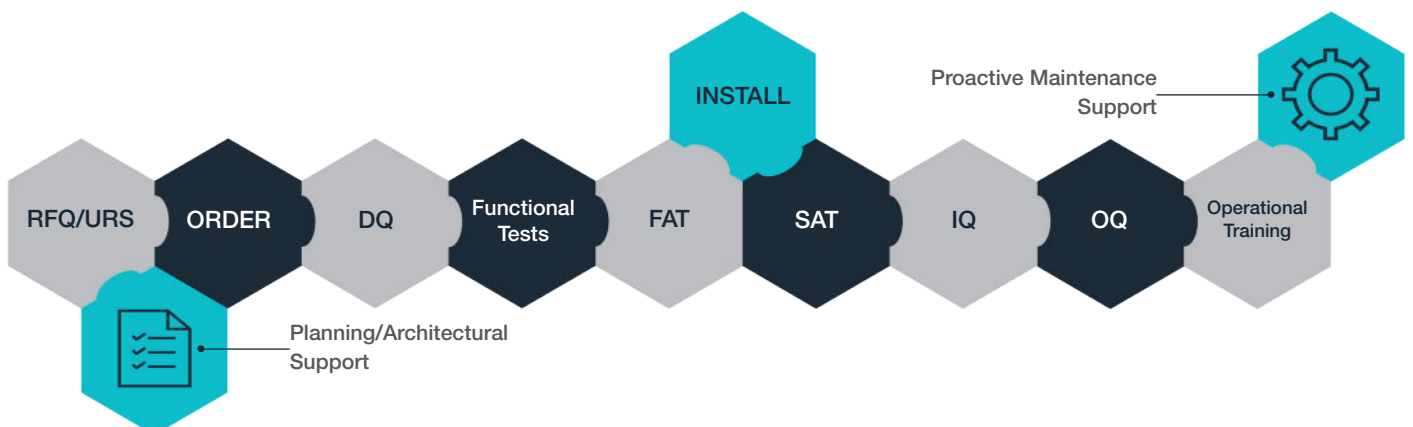



Wall Mounted Hatch Description



PBSC's transfer hatches are available in a range of material constructions, phenolic resin, powder coated steel or polished stainless steel. Also referred to as a pass-through hatch, transfer hatch, transfer chamber, and pass box. The refined design is strong and robust and provides easy cleaning and maintenance with the reliable interlock system to aid you in the reduction of cross contamination and pressure loss whilst passing product between lower and high classification areas.

The interlock mechanism is mounted between the two skins of the hatch to reduce the risk of tamper and is available as an electro-mechanical system to provide timed interlocks for air purge cycle, UV light cycles etc...

There are minimal visible fixings or recesses on the hatch which facilitates easy cleaning and the completely frameless glass door leaf provides maximum visibility and natural light into and through the hatch.

The hatches are available with a range of features and options.

Trolley Hatch Description



The PBSC trolley hatch is designed to allow wheeled trolleys to be passed between different grade rooms. Also referred to as a floor mounted hatch, hospital box, lab box and cleanroom hatch. Available in a range of material constructions, phenolic resin, powder coated steel or polished stainless steel. With the same refined design as the wall mounted design, it is strong and robust, providing easy cleaning and maintenance with the reliable interlock system to aid you in the reduction of cross contamination and pressure loss whilst passing product between lower and high classification areas.

The interlock mechanism is mounted between the two skins of the hatch to reduce the risk of tamper and is available as an electro-mechanical system to provide timed interlocks for air purge cycle, UV light cycles etc...

The trolley hatch fixes directly to the finished flooring, providing a clean and uninterrupted floor through the hatch.

The Advantages of Ventilated Hatches are Many...

PBSC's **fan filter** option comes complete with stand alone air handling/filter system in the form of a top mounted filter fan unit. The unit is mounted on the roof panel. Maximum flow 450m³/hr, larger flows with bigger units available.

Please contact PBSC's technical department for more details.

PBSC also offer a 1-hour fire rated hatch which has been certified to BS 476.

Ventilation Options

Option 1

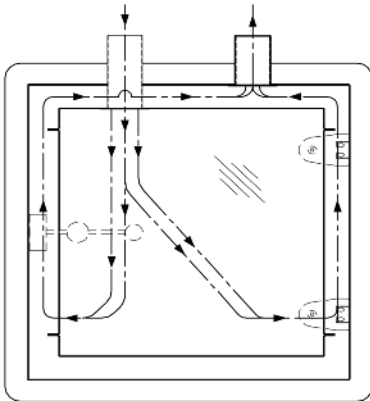

SECTION THROUGH HATCH

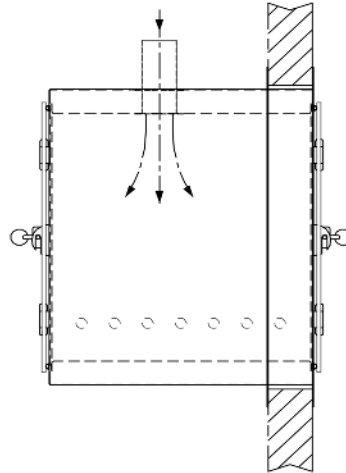

Hatch with separate supply and extract.

The hatch can be pressurized to suit requirements.

Both supply and extract air can be filtered if desired.

The extract air passes between the 2 skins of the hatch.

Option 2

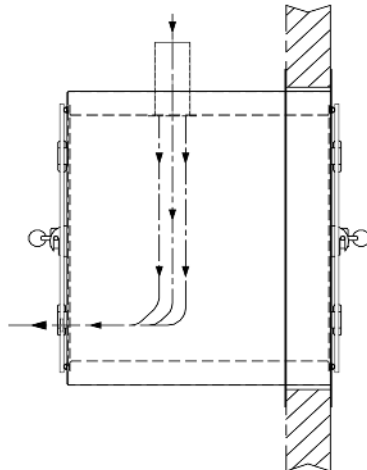
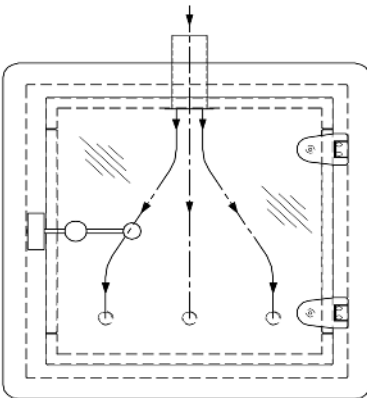

Hatch with separate supply and extract via holes in lower classification room door.

The hatch can be pressurized to suit requirements.

Both supply and extract air can be filtered if desired.

Option 3

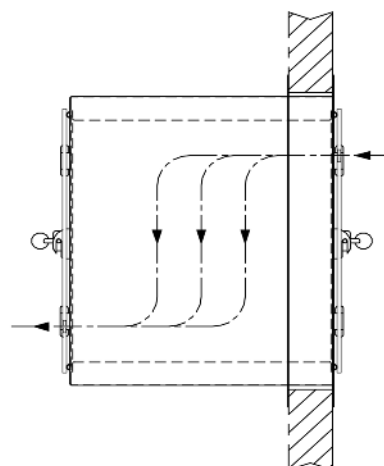
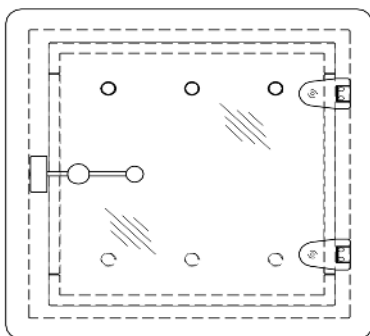

Hatch ventilated via room pressure cascades

Typically hatch pressure mid-way between the 2 adjacent rooms.

Advantages of ventilated hatches are:-

- The hatch air is “cleaned” following use to either the filtered air level of the supply or the higher classification room.
- Less risk of lower classification air entering the higher classification room.
- Electrically controlled interlocks are available to ensure hatch “air” is given time to recover before the other door can be opened.

*Air flows are indicative only.



Key Features



- Robust Mechanical Interlock as standard
- Stainless Steel or Phenolic Resin construction
- Minimal Visible Fixings
- Robust PBSC Cast Stainless Steel Hinge assemblies
- Toughened Glass Door Leaf's
- Easy Clean Surfaces
- Frameless Glass Door Leaf Providing Maximum Visibility
- Reduces Cross Contamination

Options



- Ventilated Air Supply / Extract
- Fire Resistant
- Conveyor Systems to Client Specification
- Internal Support Shelves, Glass or Stainless-Steel
- UV Lights
- Electro-Mechanical Interlock System
- Powder Coated Finish
- Stainless Steel Support Frame
- Single or Double Doors

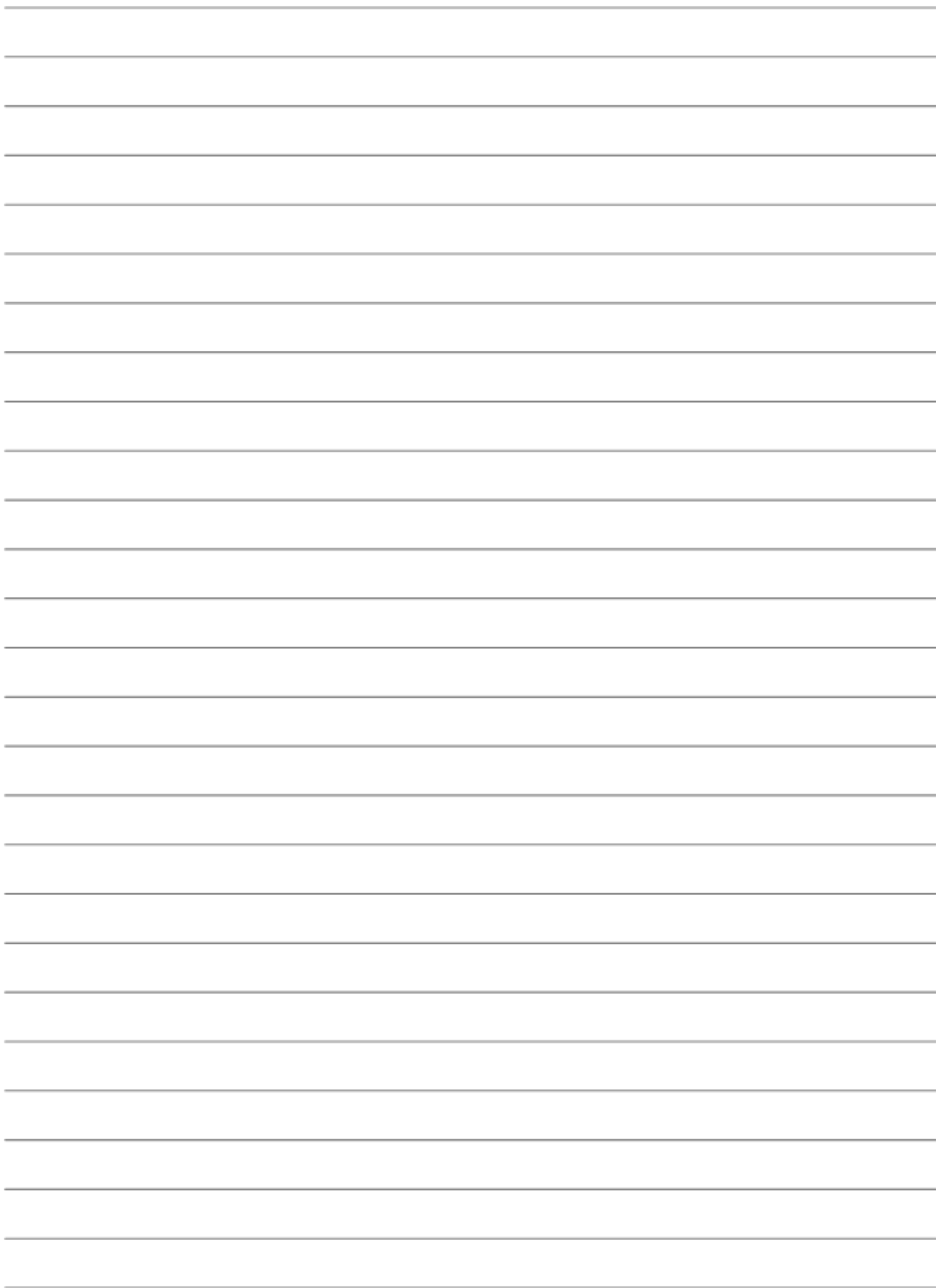

PBSC Staying in Control of Controlled Environments

Established in 1987 PBSC has become one of the leading manufacturers of clean room, high containment and material decontamination products throughout the world and having the extensive product range and bespoke designs and assembly capabilities can meet customers needs.

Providing high quality products and services to the pharmaceutical, medical research, high containment and hospital sectors, offering quick and accurate assistance during project planning to consultants, architects and end users.

PBSC have agents and representatives in most countries to provide excellent local support and logistical services to make sure your products arrive on time.

Products include;

- Clean Room Doors
- Pneumatic Inflatable Seal /Airtight Door Sets
- Mechanical Seal / Airtight Doors
- Material Decontamination Chambers
- Transfer Hatches / Cleanroom Pass Through
- Fogging Showers / Mist Showers
- Air Showers

www.pbsc.co.uk
www.pbsc-inc.com

AR-H/Ht0823

PBSC reserve the right to introduce changes in performance, configuration and technology, dimension, weights and materials in the course of technical progress. Images may not be accurate. Some of the information/images/equipment described or shown may only be available at extra cost. Features & specifications will vary. Please contact PBSC for specific design options.